

Description	High precision diaphragm vacuum regulator with high flow capacity. A balanced vacuum valve minimizes the effects of variation.
Media	compressed air or non-corrosive gases
Accuracy	response sensitivity: < 2 mbar
Adjustment	by handwheel with locknut
Gauge port	G $\frac{1}{4}$ on both sides of the body, screw plugs supplied
Mounting position	any
Temperature range	0 °C to 90 °C / 32 °F to 194 °F for appropriately conditioned compressed air down to -40 °C / -40°F
Material	Body: aluminium die-cast Elastomer: NBR/Buna-N, optionally FKM Inner valve: stainless steel, brass, aluminium and steel

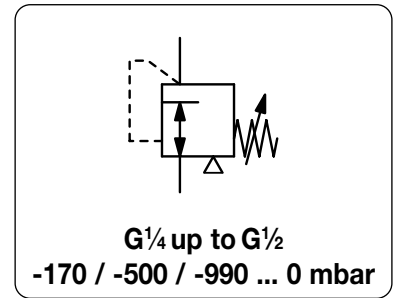

Dimensions			K _v -value (m ³ /h)	Flow rate		Connection thread G	Pressure range mbar	Order number
A	B	C		m ³ /h*	l/min*			

Precision vacuum regulator								supply pressure max. -1000 mbar, without constant bleed	V170
67	152	25	1.1	20	330	G $\frac{1}{4}$	-170 ... 0	V170-02A	
							-500 ... 0	V170-02B	
							-990 ... 0	V170-02C	
67	152	25	1.1	20	330	G $\frac{3}{8}$	-170 ... 0	V170-03A	
							-500 ... 0	V170-03B	
							-990 ... 0	V170-03C	
67	152	25	1.1	20	330	G $\frac{1}{2}$	-170 ... 0	V170-04A	
							-500 ... 0	V170-04B	
							-990 ... 0	V170-04C	



V170

Special options, add the appropriate letter

NPT	connection thread	V170-0 . . N
Verstellsicherung	made of aluminium, adjustment by screwdriver, total height 160 mm	V170-0 . . T
FKM-Elastomere		V170-0 . . V

Accessories, enclosed

pressure gauge	Ø 63 mm, -1 bar...0 bar, G $\frac{1}{4}$	MA6302-00
mounting bracket	made of steel	BW00-34

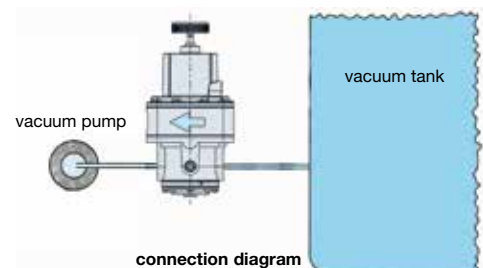
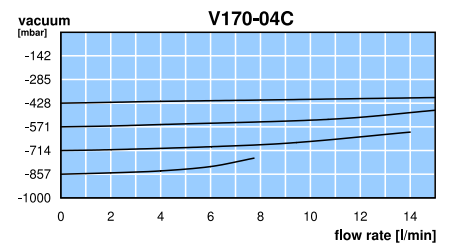
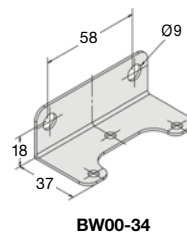
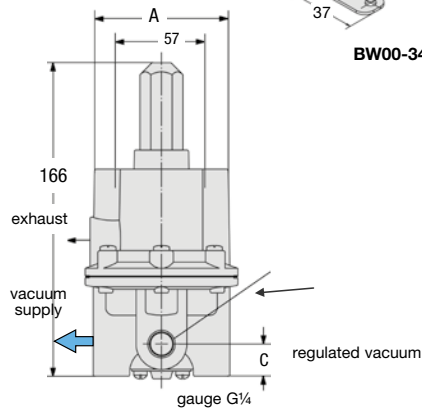
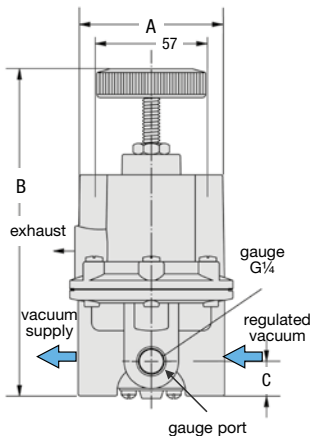
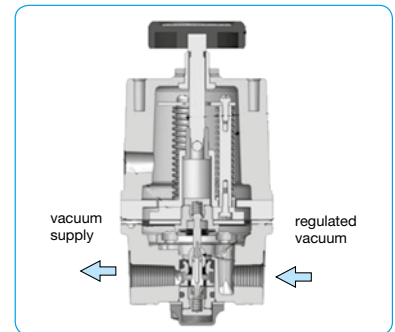

* Product group

*1 for compressed air at -0.98 bar supply pressure and 0 bar outlet pressure

